

V O L V O



Volvo Wheel Loaders 18-20.7 t 260 hp

L110H

Volvo Construction Equipment

L110H

With high breakout force, ultimate parallel movement and easy bucket filling, this medium sized 20-tonne wheel loader is ready to tackle a range of applications.



Made to move

The second generation of Volvo L110H Wheel Loader is as versatile, fuel efficient and reliable as its forerunner but it comes with a batch of improvements that increase availability. A new Volvo engine and power strategy, plus a host of maintenance-friendly features trigger benefits for the operators, service technicians and machine owners.



Fuel efficiency

- Second generation OptiShift with lockup (option)
- Reverse By Braking
- Rimpull control
- Eco pedal
- Dry P-brake

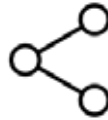

Loaded for versatility

- Unique Torque Parallel linkage
- Range of matched Volvo Attachments
- Custom built attachments
- Tailored application packages



Operator comfort

- Removed main switch, ignition key activates and powers the machine
- Choice of single or multi levers
- Choice of three hydraulic response modes
- Auto bucket leveling function
- Comfort Drive Control (option)
- Premium seat (option)



Load Assist (option)

- On-Board Weighing
- Operator Coaching
- Tire Pressure Monitoring System
- When fitted, Radar detect system, Rear-view camera and Collision Mitigation System are integrated into the Volvo Co-Pilot display



Uptime

- Auto engine regeneration while working
- 1 000 hr engine service interval
- Removed main switch = no risk of flat battery because left on
- Delayed engine shutdown reduces wear (option)



Serviceability

- Electric fuel priming pump
- Lockout-tagout (LOTO) on service switch
- Electrically-operated engine hood with large opening
- Slidable cooler installation
- Drain/fill connector for hydraulic oil
- Brake wear indicators

Volvo L110H in detail

Engine

8 liter, 6-cylinder in-line turbocharged diesel engine with an advanced common rail fuel injection system. Fuel is distributed under high pressure from a high-pressure accumulator. One camshaft-driven high pressure pump delivers the fuel to the rail and then to the electronically operated fuel injectors via high pressure pipes. The engine meets all emission requirements and comply with Stage V emission legislation by the help of the exhaust after treatment system (EATS) which contains the diesel oxy-catalyst (DOC) and diesel particulate filter (DPF) for regeneration, urea injector, mixing chamber, SCR and slipcat for reduction of NOx. The reduction of NOx is assisted by the use of cooled exhaust gas recirculation (EGR) as well.

Engine	Volvo	D8M
Max. power at	r/min	1 500 - 2 240
ISO 14396 gross	kW	191
	hp	260
ISO 9249, SAE J1349 net	kW	191
	hp	260
Max. torque at	r/min	1 450
ISO 14396 gross	Nm	1 246
ISO 9249, SAE J1349 net	Nm	1 246
Economic working range	r/min	850 - 2 100
Displacement	l	7.8

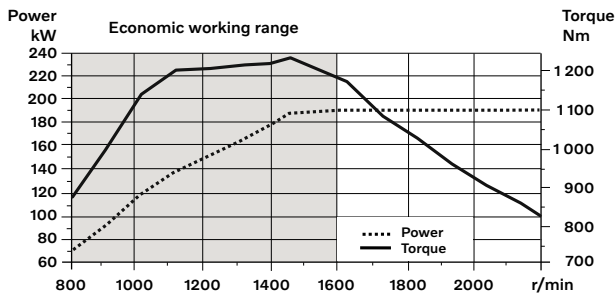

Drivetrain

Torque converter: Single-stage.

Transmission: Volvo countershaft transmission with single lever control. Fast and smooth shifting of gears with Pulse Width Modulation (PWM) valve.

Transmission: Volvo Automatic Power Shift (APS) with fully automatic shifting 1-4 and mode selector with 4 different gear shifting programs, including AUTO. Also equipped with Rimpull control to avoid wheel spin and optimize bucket filling. OptiShift transmission is also available as an option (HTL 206E).

Axles: Volvo fully floating axle shafts with planetary hub reductions and cast steel axle housing. Fixed front axle and oscillating rear axle. 100% differential lock on the front axle. Optional: Limslip rear.

Transmission	Volvo	HTE 206F
Torque multiplication, stall ratio		2.47:1
Maximum speed, forward/reverse		
1st gear	km/h	7.3
2nd gear	km/h	13.7
3rd gear	km/h	28.4
4th gear	km/h	40
Note: 4th gear limited by ECU		
Measured with tires		750/65R25
Front axle/rear axle		AWB 31/AWB 30
Rear axle oscillation	± °	13
Ground clearance at oscillation	mm	430

Electrical system

Central warning system: Contrinsic electrical system with central warning light and buzzer for following functions: - Serious engine fault - Low steering system pressure - Over speed warning engine - Interruption in communication (computer fault) Central warning light and buzzer with the gear engaged for the following functions. - Low engine oil pressure - High engine oil temperature - High charge air temperature - Low coolant level - High coolant temperature - High crank case pressure - Low transmission oil pressure - High transmission oil temperature - Low brake pressure - Engaged parking brake - Fault on brake charging - Low hydraulic oil level - High hydraulic oil temperature - Overspeeding in engaged gear - High brake cooling oil temperature front and rear axles.

Voltage	V	24
Batteries	V	2 x 12
Battery capacity	Ah	2 x 170
Cold cranking capacity, approx	A	1 000
Alternator rating	W/A	3 479/130
Starter motor output	kW	5.5

Brake system

Service brake: Volvo dual-circuit system with nitrogen charged accumulators. Outboard mounted hydraulically operated, fully sealed oil circulation cooled wet disc brakes. The operator can select automatic declutch of the transmission when braking by selecting the setting in the contronics.

Parking brake: Dry disc brake. Applied by spring force, electro-hydraulic release with a switch on the instrument panel.

Secondary brake: Dual brake circuits with rechargeable accumulators. One circuit or the parking brake fulfills all safety requirements.

Standard: The brake system complies with the requirements of ISO 3450.

Number of brake discs per wheel		1
Accumulators	l	3 x 1.0
Accumulators for parking brake	l	1 x 1.0

Cab

Refrigerant of the type R134a is used when this machine is equipped with air conditioning. Contains fluorinated greenhouse gas R134a, Global Warming Potential 1.430 t CO₂-eq.

Emergency exit: Use emergency hammer to break window

Ventilation	m ³ /min	9
Heating capacity	kW	16
Air conditioning (optional)	kW	7.5

Lift Arm System

Torque Parallel linkage (TP-linkage) with high breakout torque and parallel movement throughout the entire lifting range.

Lift cylinders		2
Cylinder bore	mm	150
Piston rod diameter	mm	80
Stroke	mm	676
Tilt cylinder		1
Cylinder bore	mm	210
Piston rod diameter	mm	110
Stroke	mm	412

Hydraulic system

System supply: Two load-sensing axial piston pumps with variable displacement. The steering system always has priority.
Valves: Double-acting 2-spool valve. The main valve is controlled by a 2-spool pilot valve.
Lift function: The valve has four positions; raise, hold, lower and floating position. Inductive/magnetic automatic boom kickout can be switched on and off and is adjustable to any position between maximum reach and full lifting height.
Tilt function: The valve has three functions including rollback, hold and dump. Inductive/magnetic automatic tilt can be adjusted to the desired bucket angle.
Cylinders: Double-acting cylinders for all functions
Filter: Full flow filtration through 10 micron (absolute) filter cartridge.

Working pressure maximum, pump 1 for working hydraulic system	MPa	27.0 ± 0.5
Flow	l/min	128
at	MPa	10
engine speed	r/min	1 900
Working pressure maximum, pump 2 for steering-, brake-, pilot- and working hydraulic system	MPa	29.0 ± 0.5
Flow	l/min	128
at	MPa	10
engine speed	r/min	1 900
Working pressure maximum, pump 3 for brake- and cooling fan system	MPa	21.0 ± 0.5
Flow	l/min	33
at	MPa	10
engine speed	r/min	1 900
Pilot system, working pressure	MPa	3.5 ± 0.5
Cycle times		
Lift	s	5.4
Tilt	s	2.1
Lower, empty	s	2.5
Total cycle time	s	10

Raise and tilt cycle times with load according to ISO 14397

Steering System

Steering system: Load-sensing hydrostatic articulated steering.
System supply: The steering system has priority feed from a load-sensing axial piston pump with variable displacement.
Steering cylinders: Two double-acting cylinders.

Steering cylinders		2
Cylinder bore	mm	75
Rod diameter	mm	50
Stroke	mm	486
Working pressure	MPa	26.5
Maximum flow	l/min	128
Maximum articulation	± °	40

Service Refill

Service accessibility: Electrically openable engine hood with large opening angle giving excellent access to the engine compartment. Fluid filters and component breather air filters promote long service intervals. A quick-fit adapter on the hydraulic tank provides faster hydraulic oil fill. Possibility to monitor, log and analyze data to facilitate troubleshooting.

Fuel tank	l	270
DEF/AdBlue® tank	l	31
Engine coolant	l	38
Hydraulic oil tank	l	140
Transmission oil	l	38
Engine oil	l	30
Axle oil front	l	36
Axle oil rear	l	41

Sound Level

Sound pressure level in cab according to ISO 6396		
L _{pA}	dB	68
External sound level according to ISO 6395 and EU Noise Directive 2000/14/EC		
L _{WA}	dB	106

Specifications

DIMENSIONS

Tires 23.5 R25 L3		L110H	
		Standard boom	Long boom
B	mm	6 550	7 080
C	mm	3 200	3 200
D	mm	440	430
F	mm	3 380	3 380
G	mm	2 131	2 133
J	mm	3 710	4 220
K	mm	4 030	4 550
O	°	55	74
P _{max}	°	50	47
R	°	41	41
R ₁ *	°	43	47
S	°	66	43
T	mm	95	106
U	mm	430	560
X	mm	2 070	2 070
Y	mm	2 670	2 670
Z	mm	3 340	3 330
a ₂	mm	5 730	5 730
a ₃	mm	3 060	3 060
a ₄	±°	40	40
With 3.0 m ³ STE H T bucket			

* Carry position SAE

Where applicable, specifications and dimensions are according to ISO 7131, SAE J732, ISO 7546, SAE J742, ISO 14397, SAE J818.

L110H Log Loader

Grapple: WLA80832

Operating weight

(incl. logging cw 685 kg): 20 070 kg

Operating load: 6 500 kg

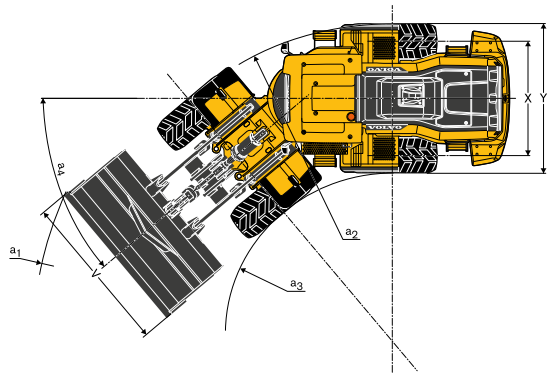
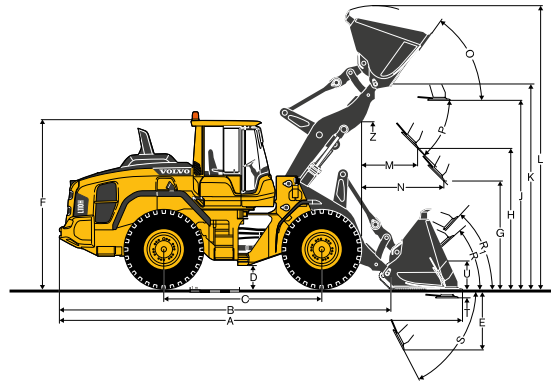

DIMENSIONS

		L110H
		Tires: 750/65 R25
A	m ²	2.4
B	mm	3 480
C	mm	1 850
D	mm	2 860
E	mm	1 460
F	mm	1 530
G	mm	2 720
H	mm	4 600
I	mm	6 630
J	mm	2 790
K	mm	2 990
L	mm	2 050
M	mm	8 830

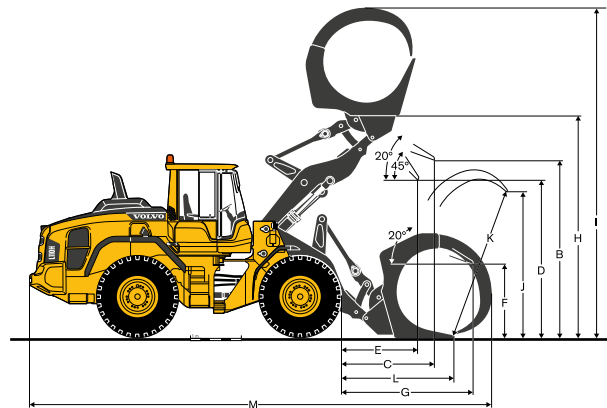

L110H

Tires 23.5R25 XHA2 L3		REHANDLING*		GENERAL PURPOSE				ROCK**	LIGHT MATERIAL		LONG BOOM***
		3.5 m ³ STE P BOE	3.5 m ³ STE H BOE	3.0 m ³ STE P T	3.0 m ³ STE H T	3.4 m ³ STE P BOE	3.4 m ³ STE H BOE	2.7 m ³ SPN P T SEG	5.5 m ³ LM H	9.5 m ³ LM H	3.0 m ³ STE H T
Volume, heaped ISO/SAE	m ³	3.5	3.5	3.0	3.0	3.4	3.4	2.7	5.5	9.5	3.0
Volume at 110% fill factor	m ³	3.9	3.9	3.3	3.3	3.7	3.7	3.0	6.1	10.5	3.3
Static tipping load, straight	kg	14 790	14 100	13 860	13 150	13 580	12 920	13 820	12 060	12 160	-530
at 35° turn	kg	13 150	12 500	12 340	11 670	12 080	11 470	12 260	10 640	10 700	-520
at full turn	kg	12 660	12 030	11 890	11 240	11 630	11 040	11 800	10 220	10270	-530
Breakout force	kN	173.1	160.0	179.7	165.5	171.5	158.5	153.0	123.1	107.3	+3
A	mm	8 040	8 150	8 110	8 220	8 060	8 160	8 390	8 580	8 880	+510
E	mm	1 220	1 320	1 280	1 380	1 230	1 330	1 520	1 700	1 960	-310
H	mm	2 820	2 750	2 780	2 710	2 810	2 740	2 600	2 420	2 210	+510
L	mm	5 580	5 650	5 430	5 490	5 500	5 570	5 540	5 840	6 010	+520
M	mm	1 170	1 250	1 220	1 300	1 180	1 260	1 400	1 520	1 730	-40
N	mm	1 720	1 760	1 740	1 780	1 720	1 760	1 810	1 800	1 810	+440
V	mm	3 000	3 000	2 880	2 880	2 880	2 880	2 880	3 000	3 400	0
a ₁ clearance circle	mm	12 930	12 980	12 860	12 910	12 830	12 880	13 040	13 260	13 810	+480
Operating weight	kg	19 360	19 580	18 520	18 750	18 580	18 800	19 710	19 260	19 480	+250

* Measured with additional rehandling counterweight | ** With MICHELIN 23,5R25 XMINE D2 Pro L5 Tire | *** Compared to GP 3.0 m³ STE H T bucket

Bucket Selection Chart

The chosen bucket is determined by the density of the material and the expected bucket fill factor. The actual bucket volume is often larger than the rated capacity, due to the features of the TP linkage, including an open bucket design, good rollback angles in all positions and good bucket filling performance. The example represents a standard boom configuration. Example: Sand and gravel. Fill factor ~ 105%. Density 1.6 t/m³. Result: The 3.4 m³ bucket carries 3.6 m³. For optimum stability always consult the bucket selection chart.

Material	Bucket fill, %		Material density, t/m ³	ISO/SAE bucket volume, m ³	Actual volume, m ³
Earth/Clay	~ 110		1.8	3.0	3.3
			1.6	3.4	3.7
Sand/Gravel	~ 105		1.8	3.0	3.2
			1.6	3.4	3.6
Aggregate	~ 100		1.8	3.5	3.5
Rock	≤100		1.7	2.7	2.7

The size of rock buckets is optimized for optimal penetration and filling capability rather than the density of the material.

Type of boom	Type of bucket	ISO/SAE Bucket volume	L110H Material density (t/m ³)							
			0.8	1.0	1.2	1.4	1.6	1.8	2.0	
Standard boom	Rehandling	P 3.5 m ³								
		H 3.5 m ³								
	General purpose	P 3.0 m ³								
		H 3.0 m ³								
		P 3.4 m ³								
	H 3.4 m ³									
Rock	P 2.7 m ³									
Long boom	Light material	H 5.5 m ³								
		H 9.5 m ³								
	Rehandling	P 3.5 m ³								
		P 3.0 m ³								
General purpose	P 3.4 m ³									
	P 2.7 m ³									
Light material	H 5.5 m ³									

How to read bucket fill factor

Supplemental Operating Data

Tires 23.5 R25 L3	Standard boom		Long boom
	23.5 R25 L5	750/65 R25	750/65 R25
Width over tires	mm	+30	+200
Ground clearance	mm	+50	0
Tipping load, full turn	kg	+490	+430
Operating weight	kg	+670	+640

Equipment

STANDARD EQUIPMENT

Engine

Exhaust after-treatment system
 Three stage air cleaner, pre-cleaner, primary and secondary filter
 Indicator for coolant level
 Preheating of induction air
 Fuel pre-filter with water trap
 Fuel filter
 Electric fuel prime pump
 Crankcase breather oil trap
 Exterior radiator air intake protection

Drivetrain

Automatic Power Shift
 Fully automatic gearshifting, 1-4
 PWM-controlled gearshifting
 Forward and reverse switch by hydraulic lever console
 Rimpull control
 Indicator glass for transmission oil level
 Differentials: Front, 100% hydraulic diff lock. Rear, conventional.

Electrical system

24 V, pre-wired for optional accessories
 Alternator 24 V / 130 A / 3 479 W
 Battery disconnect (service) switch
 Fuel gauge
 Hour meter
 Electric horn
 Instrument cluster:
 Fuel level
 Diesel Exhaust Fluid/AdBlue level
 Transmission temperature
 Coolant temperature
 Instrument lighting

Lighting:

Twin halogen front headlights with high and low beams
 Parking lights
 Double brake and tail lights
 Turn signals with flashing hazard light function
 Halogen work lights (2 front and 2 rear)

STANDARD EQUIPMENT

Contronic monitoring system

Monitoring and logging of machine data
 Contronic display
 Fuel consumption
 Diesel Exhaust Fluid / AdBlue consumption
 Ambient temperature
 Clock
 Test function for warning and indicator lights
 Brake test
 Test function, sound level at max fan speed

Warning and indicator lights:
 Battery charging
 Parking brake

Warning and display message:

Regeneration
 Engine coolant temperature
 Charge-air temperature
 Engine oil temperature
 Engine oil pressure
 Transmission oil temperature
 Transmission oil pressure
 Hydraulic oil temperature
 Brake pressure
 Parking brake applied
 Brake charging
 Overspeed at direction change
 Axle oil temperature
 Steering pressure
 Crankcase pressure
 Attachment lock open
 Safety Belt Warning

Level warnings:

Fuel level
 Diesel Exhaust Fluid/AdBlue level
 Engine oil level
 Engine coolant level
 Transmission oil level
 Hydraulic oil level
 Washer fluid level

Engine torque reduction in case of malfunction indication:

High engine coolant temperature
 High engine oil temperature
 Low engine oil pressure
 High crankcase pressure
 High charge-air temperature

Engine shutdown to idle in case of malfunction indication:

High transmission oil temperature
 Slip in transmission clutches

Keypad, background lit

Start interlock when gear is engaged

Hydraulic system

Main valve, double acting 2-spool with hydraulic pilots

Variable displacement axial piston pumps (3) for:

- 1 Working hydraulics, Pilot hydraulics and Brake system
- 2 Working hydraulics, Pilot hydraulics, Steering and Brake system
- 3 Cooling fan and Brake system

Secondary steering with automatic test function

Quick hydraulic oil fill

Electro-hydraulic servo controls

Electronic hydraulic lever lock

Automatic boom kick-out

Automatic bucket positioner

Double-acting hydraulic cylinders

Indicator glass for hydraulic oil level

Hydraulic oil cooler

STANDARD EQUIPMENT

Brake system

Dual brake circuits
Dual brake pedals
Secondary brake system
Parking brake, electro-hydraulic
Brake wear indicators

Cab

ROPS (ISO 3471), FOPS (ISO 3449)
Harness Anchor Points
Single key kit door/start
Acoustic inner lining
Cigarette lighter, 24 V power outlet
Lockable door
Cab heating with fresh air inlet and defroster
Fresh air inlet with two filters
Automatic heat control
Floor mat
Dual interior lights
Interior rear-view mirrors
Dual exterior rear-view mirrors
Sliding window, right side
Tinted windshield glass
Retractable seatbelt (SAE J386)
Adjustable steering wheel
Storage compartment
Document pocket
Sun visor
Beverage holder
Windshield washer front and rear
Windshield wipers front and rear
Interval function for front and rear wipers

Service and maintenance

Engine oil remote drain and fill
Transmission oil remote drain and fill
Lubrication manifolds, ground accessible
Pressure check connections: transmission and hydraulic, quick-connects
Quick-fit hydraulic oil fill
Tool box, lockable

External equipment

Orange hand rails
Fenders, front and rear
Viscous cab mounts
Rubber engine and transmission mounts
Frame, joint lock
Vandalism lock prepared for
 Engine compartment
 Radiator grille
Lifting eyes
Tie-down eyes
Fabricated counterweight
Counterweight, pre-drilled for optional guards

Equipment

OPTIONAL EQUIPMENT

Engine

Air pre-cleaner, cyclone type
 Air pre-cleaner, oil-bath type
 Air pre-cleaner, turbo type II
 Air pre-cleaner, turbo type III
 Engine auto shutdown
 Engine delayed shutdown
 Engine block heater
 Fuel fill strainer
 Fuel heater
 Hand throttle control
 Max. fan speed, hot climate
 Radiator, corrosion-protected
 Reversible cooling fan
 Reversible cooling fan and axle oil cooler

Wheels and tires

23.5 R25
 750/65 R25

Drivetrain

Oil cooler and filter front & rear axle
 OptiShift transmission with Lock-up RBB
 Diff lock front 100%, Limited Slip rear
 Agri power-shift / lock-up 1-4
 Speed limiter
 Stainless steel, brake lines

OPTIONAL EQUIPMENT

Electrical system

Anti-theft device
 Halogen Economy package
 Halogen Feature package
 Halogen Power package
 Headlights, assymetric left, halogen
 Working lights, attachments, halogen
 LED Economy package
 LED Feature package
 LED Power package
 LED Intense package
 Alarm kit, anti-theft function in WECU
 Battery disconnect switch, additional in cab
 Emergency stop
 Locking device, Tag out Lock out
 License plate holder, lighting
 Rear view camera, monitor
 Rear view mirrors, el.adjusted and heated
 Rear view mirrors, long arm right
 Rear view mirrors, el.adjusted and heated, long arm right
 Reduced function working lights, reverse gear activated
 Reverse alarm, audible
 Reverse alarm, white noise
 Dual LED reversing strobe lights
 Seatbelt indicator, external
 Shortened headlight support brackets
 Side marker lamps
 Warning beacon LED
 Warning beacon LED automatic
 Electrical distribution unit 24 volt
 Load Assist
 Radar detect system
 Collision Mitigation System
 Forward camera
 Dual forward cameras
 Parking brake alarm, audible for air susp seats
 Jump start connector, ISO-Type
 Max Boom height
 Can Bus Interface
 Delayed Engine Shutdown
 Co-Pilot available
 Rearview camera in Co-Pilot
 OnBoard Weighing
 OnBoard Weighing Task Mode
 Tire pressure monitoring system
 Connected Map
 Operator Coaching Start
 Operator Coaching Advanced

Hydraulic system

Boom suspension system
 Separate attachment locking
 Arctic kit, attachment locking hoses
 Boom cylinder hose and tube guards
 Hydraulic fluid, biodegradable, Volvo
 Hydraulic fluid, fire-resistant
 Hydraulic fluid, for hot climate
 Hydraulic 3rd function
 Hydraulic 3rd-4th function
 Hydraulic constant flow control with detent for 3rd function
 Single lever control, hydraulics 2 functions
 Single lever control, hydraulics 3 functions
 Single lever control, hydraulics 4 functions

OPTIONAL EQUIPMENT

Cab

Anchorage for Operator's manual
Automatic Climate Control, ACC
ACC control panel, with Fahrenheit scale
Asbestos dust protection filter
Ashtray
Cab air pre-cleaner, cyclone type
Carbon filter
Cover plate, under cab
Lunch box holder
Volvo Armrest, operator's seat, left
Operator's seat, Mechanical ISRI, 2pt seat belt
Operator's seat, Volvo Air Suspension, Heavy Duty, 2pt seat belt
Operator's seat, Volvo Air Suspension, 2pt seat belt
Operator's seat, Volvo Air Suspension, 3pt seat belt
Operator's seat, Comfort ISRI, 2pt seat belt
Operator's seat, Comfort ISRI, 3pt seat belt
Operator's seat, Premium ISRI, 2pt seat belt
Operator's seat, Premium ISRI, 3pt seat belt
Radio installation kit incl. 12 volt outlet, left side
Radio installation kit incl. 12 volt outlet, right side
Radio (with AUX, Bluetooth and USB connection)
DAB Radio
Subwoofer
Steering wheel knob
Sun blinds, rear windows
Sun blinds, side windows
Timer cab heating
Window, sliding, door
Universal door/ignition key
Remote door opener
Forward view mirrors
Cab heater power outlet 240 V
Cab, Hot applications. Roof, steel
Fire extinguisher cab
Outside steel protection cab
Rear view mirrors long arm, cab
Reinforced windshield, flat

Service and maintenance

Automatic lubrication system
Automatic lubrication system for long boom
Grease nipple guards
Oil sampling valve
Refill pump for grease to lube system
Tool kit
Wheel nut wrench kit
CareTrack, GSM, GSM/Satellite
Telematics, Subscription

OPTIONAL EQUIPMENT

Protective equipment

Belly guard front
Belly guard rear
Cover plate, heavy-duty, front frame
Cover plate, rear frame
Cover plate, front/rear axle
Cab roof, heavy-duty
Guards for front headlights
Guards for radiator grill
Guards for tail lights
Windows, side and rear guards
Windshield guard
Wheel/axle seal guards
Corrosion protection, painting of machine
Corrosion protection, painting of attachment bracket
Bucket Teeth protection

External equipment

Cab ladder, rubber-suspended
Deleted front mudguards & wideners rear
Handles on counterweight
Fire suppression system
Mudguards, full cover, rear for 80-series tires
Mudguards, full cover, rear for 65-series tires
Long boom
Tow hitch

Other equipment

CE-marking
Comfort Drive Control (CDC)
Counterweight, logging
Counterweight, signal painted, chevrons
Sound decal, EU
Sound decal, USA
Reflecting stickers (decals), machine contour
Reflecting stickers (stripes), machine contour Cab
Option for machines without dinitrol
Noise reduction kit, exterior
Sign, slow moving vehicle
Sign, 50 km/h
Agriculture package
Log Loader package
Rehandling package
Scrap Handler package
Waste Handler package

Attachments

Buckets:
Rock straight or spade nose
General purpose
Rehandling
Light material
High tip
Grading
Wear parts:
Bolt-on and weld-on bucket teeth
Segments
Cutting edge in three sections, bolt-on
Fork equipment
Material handling arm
Log grapples
Snow plows
Spreading bucket
Sweepers

V O L V O