



Volvo Construction Equipment

ECR58D

VOLVO EXCAVATORS 5.7-7.0 t 50 hp





Enhanced hydraulics

Volvo's state-of-the-art hydraulic system is perfectly matched to the Volvo engine and components – delivering high performance and improved fuel efficiency. The hydraulic system has been designed for fast response and smooth operation.

Powered to perform.

Introducing the Volvo ECR58D, a compact short swing radius excavator that delivers a powerful, efficient performance. Whether you're working in the road construction, utilities, landscaping or any other application, the ECR58D gives you precise control and smooth operation.



Volvo engine

Volvo's premium engine features proven technology to deliver superior performance and low fuel consumption. Benefit from reduced operating costs and low emission levels for high efficiency and environmental care.

Slew and boom offset

Slew and boom offset movements are controlled simultaneously for easy and fast positioning of the machine. Joystick control enables precise, smooth and effortless command of the slew and boom offset.



Tractive force

High system pressure delivers impressive tractive force when climbing gradients or traveling over rough terrain. For improved performance, the ECR58D features a 5% improvement in tractive force compared to the previous model.

Superior stability.

If you're looking for the performance of a conventional excavator but need to work in confined areas, the Volvo ECR58D is the machine for you. With a heavy counterweight and strong undercarriage you can lift larger loads without buying a bigger machine. Volvo offers customers built-in serviceability with safe and convenient maintenance access for maximum uptime.

Single pivot pin

Volvo uses a single pivot design that achieves maximum support between main frame and front equipment. This concept increases stability, durability and lifetime of the components.



Service access

For safe and easy access, all service check points are located under the wide-opening engine hood and are accessed from ground level. Grouped filters ensure regular maintenance is straightforward and uptime is maximized.



MATRIS and VCADS Pro

For increased uptime, Volvo's high-tech, computer-based MATRIS tool allows you to monitor machine usage and analyze machine operation. VCADS Pro analysis and programming software provides fast diagnostics.



Stability

Design improvements including a counterweight have shifted the center of gravity towards the rear of the machine. Together with a strong undercarriage, this delivers superior stability while lifting bigger loads.



Volvo Cab

All-around visibility from slim cab pillars and large expanses of glass is at the center of Volvo's cab design. The ROPS certified cab features vibration and noise isolation, ergonomic controls and an adjustable seat for increased comfort, reduced fatigue and increased productivity.

The ECR58D has been expertly designed with the operator in mind. With built in safety, comfort and all-around visibility, operators will work efficiently with less fatigue in this premium environment. Capitalize on comfort and optimize your productivity with Volvo.

Control in comfort.

Climate control

Control your climate with Volvo's powerful, industry-leading climate control system. With seven well-spaced vents quickly heating or cooling the cab, this air circulation and defrosting system increases comfort and productivity.

Keypad

The majority of switches are integrated in one centralized keypad on the right-hand console. The operator can easily control the I-ECU monitor and audio system for increased comfort.



Proportional joysticks

Via the joystick controls, the operator can easily adjust the direction and amount of hydraulic flow sent to the attachment. Benefit from the correct speed and power for optimal attachment operation.

Storage

The Volvo cab features ample storage locations for personal belongings including an additional glove-box, side pocket, phone storage, cup holder and a pocket behind the seat.



Hydraulic breakers

Volvo's durable hydraulic breakers have been designed for ultimate compatibility with Volvo excavators. The range has been built to break the most demanding materials and combines excellent performance with low noise and vibration levels.

Infinite opportunities.

Get the most out of your compact short swing radius excavator and access more segments and applications with Volvo's comprehensive range of attachments – designed to work in perfect harmony with Volvo machines. Increase your versatility, effectively perform a variety of tasks and experience new levels of productivity with the right attachment for your specific requirements.

Interfaces

Direct fit



For maximum productivity when only operating in one application, Volvo's direct fit attachments provide the best performance and shortest tip radius.

Volvo mechanical quick coupler



Volvo's dedicated quick couplers pick up Volvo hydraulic attachments including breakers, thumbs and buckets for use in both the face shovel and normal backhoe position.

Volvo hydraulic quick coupler



Volvo's pin grabber quick coupler picks up Volvo pin-on Attachments, including breakers, thumbs and buckets for use in both the face shovel and normal position.

Buckets

General purpose buckets

The perfect tool for trenching and handling in a variety of soil conditions. Available in different widths.

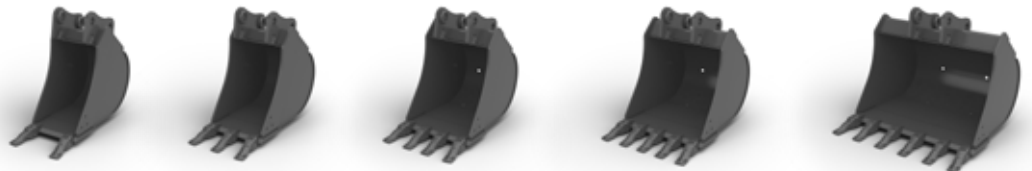

Fixed ditching buckets

Ideal for ditch cleaning, grading, landscaping and backfilling.



Tiltable ditching bucket

This bucket can be tilted 45° to each side making it a flexible and versatile solution for grading, landscaping, ditch cleaning and backfilling.



Volvo hydraulic thumb

Designed to work with both Volvo direct fit buckets and with quick coupler in various materials. Used for piling, placing, loading, lifting and carrying.

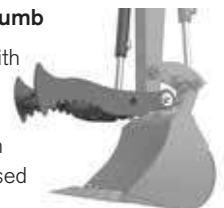

Volvo Tooth System and wear parts



General purpose

Self-sharpening, general purpose tooth with good penetration and long service life.



Twin pick

Twin pick point with sharp, dual point profile. Ideal for compact or frozen ground.



Pick point

Intended for use in extremely compact materials.



Spade nose

Designed for finishing work such as leveling, grading, cleaning and backfilling.



Bottom leg adapter

A long (one and a half) bottom leg adapter for welding to both sides of the cutting edge.



Side cutter

Side cutters ensure longer bucket life by protecting the side plates and corner welds.

Take a closer look.



Hydraulics

The hydraulic system is perfectly matched to the engine and components for fast response and smooth operation.

Auto-idle

Engine speed is reduced to idle when the controls are inactive for more than five seconds or the left-hand console is raised – reducing fuel consumption and noise.

Optional hydraulics

For increased versatility, auxiliary hydraulic systems are available to enable the operation of a wide range of attachments.

MATRIS and VCADS Pro

The MATRIS tool monitors machine usage and operation. VCADS Pro analysis and programming software provides fast diagnostics.

Optional dozer floating

The optional dozer blade float function 'floats' the dozer blade over the ground for improved leveling control and fuel efficiency.



**Cab**

Volvo's purpose designed cab offers excellent all-round viability, enhanced by the slim cab pillars and large windows.

**Service access**

All service check points are accessed from ground level. Grouped filters make regular maintenance easy.

**Volvo engine**

Premium Volvo Engine delivers superior performance with low fuel consumption.

**Stability**

A heavy counterweight and a strong undercarriage deliver superior stability and the ability to lift bigger loads.

**Single pivot pin**

Volvo uses a single pivot design that achieves maximum support between main frame and front equipment, This concept increases, stability, durability and lifetime of the components

Undercarriage

Durable and strong X-shape undercarriage ensures superior stability and increases machine lifetime.

Adding value to your business.

Being a Volvo customer means having a complete set of services at your fingertips. Volvo can offer you a long-term partnership, protect your revenue and provide a full range of customer solutions using high quality parts, delivered by passionate people. Volvo is committed to increasing the positive return on your investment and maximising uptime.



Customer Support Agreements

The range of Customer Support Agreements offer preventive maintenance, total repairs and a number of uptime services.

Volvo uses the latest technology to monitor machine operation and status, giving you advice to increase your profitability. By having a Customer Support Agreement you are in control of your service costs.



Genuine Volvo Parts

Our attention to detail is what makes us stand out. This proven concept acts as a solid investment in your machine's future. Parts are extensively tested and approved because every part is vital for uptime and performance. Only by using Genuine Volvo Parts, can you be sure that your machine retains the renowned Volvo quality.



Service Network

In order to respond to your needs faster, a Volvo expert is on their way to your job site from one of our Volvo facilities. With our extensive infrastructure of technicians, workshops and dealers, Volvo has a comprehensive network to fully support you using local knowledge and global experience.



Complete Solutions

Volvo has the right solution for you. So why not let us provide all your needs throughout the whole life cycle of your machine? By listening to your requirements, we can reduce your total cost of ownership and increase your revenue.

Volvo ECR58D in detail.

Engine

The new diesel engine is equipped with four-cylinder, vertical, in-line, turbocharged, mechanical controlled direct injection, air to air intercooler, and water cooled.

Model	Volvo	D2.6A
Max. power at	r/s / r/min	33.3 / 2 000
Net (ISO 9249/SAE J1349)	kW / hp	35 / 48
Gross (SAE J1995)	kW / hp	36.5 / 50
Max. torque	Nm/ r/min	210 / 1 400
No. of cylinders		4
Displacement	l	2.615
Bore	mm	87
Stroke	mm	110

Electrical system

Voltage	V	12
Battery capacity	V / Ah	1 x 12 / 100
Alternator	V / Ah	12 / 60
Starter motor output	V / kW	12 / 3

Hydraulic system

Closed-Center Load-Sensing (CCLS) system with load independent functions.

Main pump: Variable-displacement pump		
Maximum flow	l/min	1 x 126
Pilot pump: Gear pump		
Maximum flow	l/min	1 x 14
Relief valve setting		
Implement	Mpa	23.5
Travel circuit	Mpa	23.5
Swing circuit	Mpa	20.6
Pilot circuit	Mpa	3.4

Swing system

Direct drive swing with radial piston motor-maintenance free type (no reduction gear) and automatic holding brake anti-rebound valve.

Max. swing speed	r/min	9.22
Max. swing torque	kNm	13.2

Undercarriage

Robust X-shaped frame with track chains.

Track shoes		2 x 39
Link pitch	mm	135
Shoe width - steel	mm	380 / 500
Shoe width - rubber	mm	400
Bottom rollers		2 x 5
Top rollers		2 x 1

Travel system

Each track is powered by an automatic two-speed shift travel motor. The track brakes are multi-disc, spring-applied and hydraulic released.

Travel speed (low / high)	km/h	2.1 / 4.2
Max. drawbar pull	kN	49
Gradeability	°	35

Service refill capacities

Fuel tank	l	65
Hydraulic system, total	l	90
Hydraulic tank	l	52
Engine oil	l	11.9
Engine coolant	l	8
Travel reduction unit	l	2 x 1.6

Sound Level

Sound level in cab according to ISO 6396

LpA (standard)	dB(A)	73
----------------	-------	----

External sound level according to ISO 6395 and EU Noise Directive 2000/14/EC

LpA (standard)	dB(A)	97
----------------	-------	----

Buckets

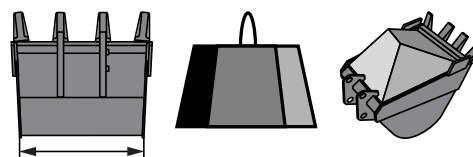

	Width mm	Weight kg	Capacity l
Direct bucket	355	97	70
	450	93	99
	600	116	144
	750	131	190
	900	149	235
Quick coupler bucket	450	105	99
	600	132	144
	750	151	190

Specifications.

DIMENSIONS

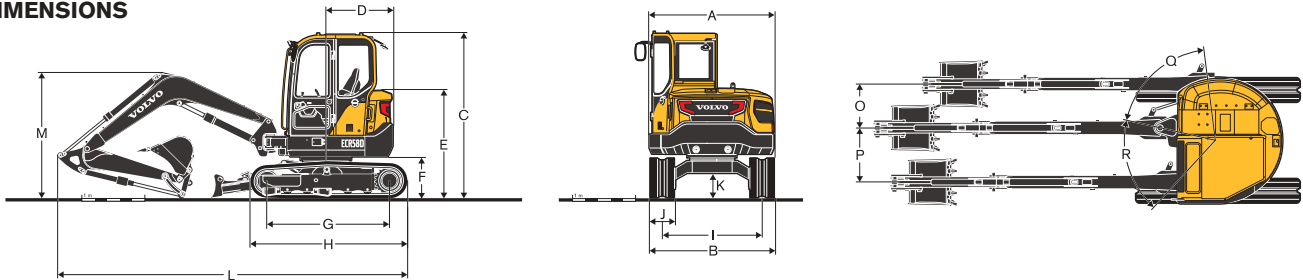

Machine

			2.9	1.94
Boom		m		
Arm		m	1.54	1.94
A	Overall width of upper structure	mm	2 000	2 000
B	Overall width	mm	2 000	2 000
C	Overall height of cab	mm	2 615	2 615
D	Tail swing radius	mm	1 060	1 060
E	Overall height of engine hood	mm	1 710	1 710
F	Counterweight clearance *	mm	670	670
G	Tumbler length	mm	1 950	1 950
H	Track length	mm	2 495	2 495
I	Track gauge	mm	1 600	1 600
J	Shoe width	mm	400	400
K	Min. ground clearance *	mm	360	360
L	Overall length	mm	5 550	5 580
M	Overall height of boom	mm	2 000	2 200
O	Boom swing distance	mm	695	695
P	Boom swing distance	mm	860	860
Q	Boom swing angle	°	70	70
R	Boom swing angle	°	60	60

* Without shoe grouser

Boom and Arm

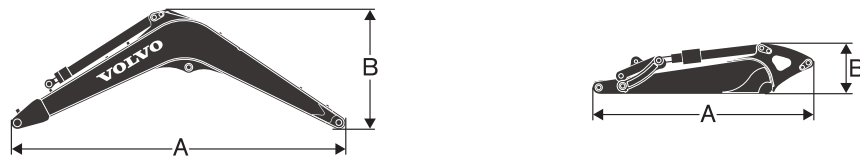

			2.9	1.54	1.94
Boom		m			
Arm		m			
A	Length	mm	3 008	2 023	2 423
B	Height	mm	1 024	459	473
	Width	mm	300	295	295
	Weight	kg	300	180	225

Boom: Includes cylinder, piping and pin, excludes boom cyl. Pin. Arm: Includes cylinder, linkage and pin.

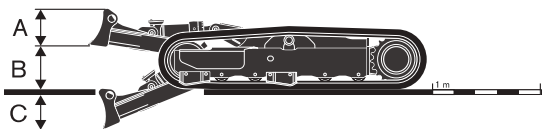

Dozer blade

A	Height	mm	373
	Width	mm	2 000
B	Lifting height	mm	442
C	Digging depth	mm	457

MACHINE WEIGHTS AND GROUND PRESSURE

	Shoe width	Operating weight	Ground pressure
	mm	kg	kPa
Mono boom 2.9 m, Arm 1.54 m, Bucket 129 kg (142 l), Counterweight 580 kg			
Steel track	380	5 940	35.7
	500	6 040	27.6
Rubber track	400	5 820	33.2
Rubber pad	400	5 975	33.8
Mono boom 2.9 m, Arm 1.94 m, Bucket 129 kg (142 l), Counterweight 580 kg			
Steel track	380	6 000	36.0
	500	6 100	27.9
Rubber track	400	5 880	33.6
Rubber pad	400	6 035	34.1

Specifications.

WORKING RANGES

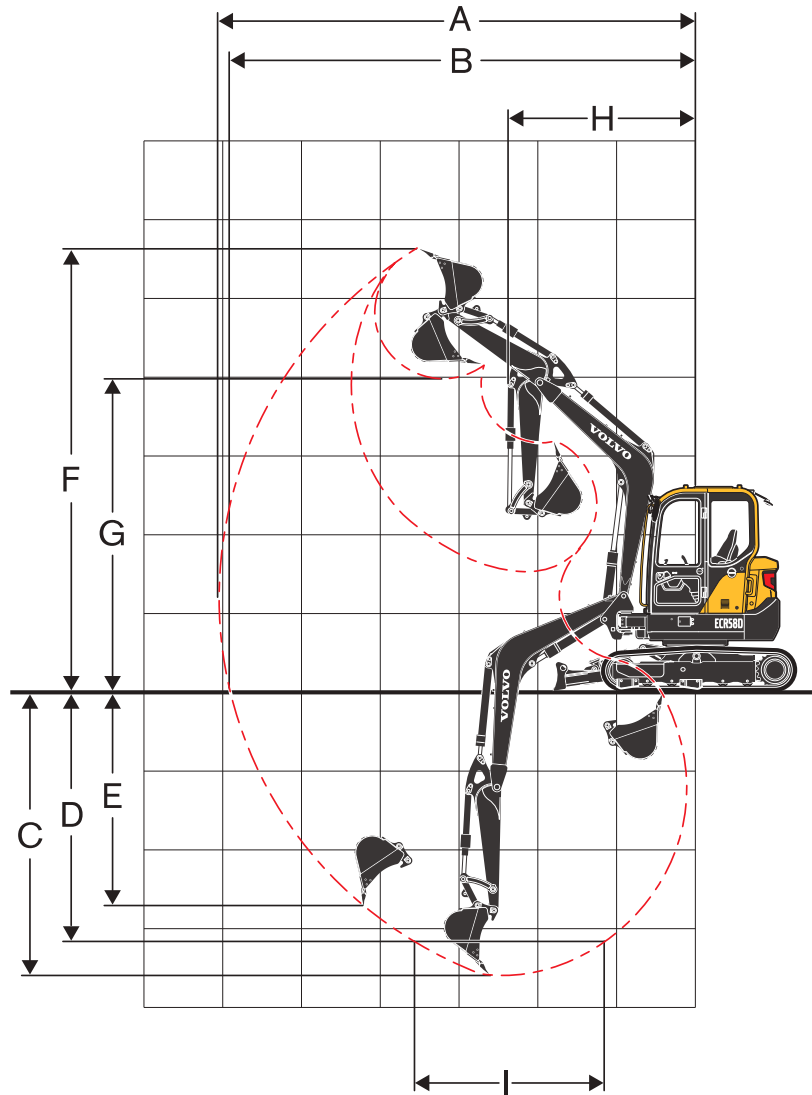

Description	Unit			
Boom	m			2.9
Arm	m		1.54	1.94
A Max. digging reach	mm		6 000	6 370
B Max. digging reach on ground	mm		5 850	6 230
C Max. digging depth	mm		3 540	3 940
D Max. digging depth (l=2 440mm level)	mm		3 100	3 550
E Max. vertical wall digging depth	mm		2 310	2 680
F Max. cutting height	mm		5 570	5 810
G Max. dumping height	mm		4 040	4 280
H Min. front swing radius	mm		2 410	2 450
Digging forces with direct fit bucket				
Breakout force (bucket)	SAE J1179	kN	34.6	34.6
	ISO 6015	kN	39.8	39.8
Tearout force (arm)	SAE J1179	kN	26.1	22.1
	ISO 6015	kN	26.6	22.5
Rotation angle, bucket		°		195

LIFTING CAPACITY ECR58D

Lifting capacity at the arm end without bucket.

For lifting capacity including bucket. Simply subtract actual weight of the direct fit bucket or the bucket with quick coupler from the following values.

	Lifting point	1.0 m		2.0 m		3.0 m		4.0 m		5.0 m		Max. reach		
		Along	Across	Along	Across	Along	Across	Along	Across	Along	Across	Along	Across	mm
Boom 2.9m	4.0 m kg							*1 110	1 000			*1 130	930	4 155
Arm 1.54m	3.0 m kg							*1 130	990			*1 100	720	4 799
Shoe 400mm	2.0 m kg					*1 790	1 490	*1 310	950	*1 120	660	*1 110	630	5 120
CWT 580kg	1.0 m kg					*2 320	1 380	*1 520	900	*1 180	640	*1 130	600	5 190
Dozer blade down	0.0 m kg					*2 450	1 330	*1 620	870	*1 170	630	*1 160	620	5 022
	-1.0 m kg	*2 460	*2 460	*3 140	2 670	*2 250	1 320	*1 520	860			*1 180	710	4 585
	-2.0 m kg			*2 590	*2 590	*1 680	1 360					*1 140	970	3 757
Boom 2.9m	4.0 m kg							*1 110	940			*1 130	880	4 155
Arm 1.54m	3.0 m kg							*1 130	930			930	680	4 799
Shoe 400mm	2.0 m kg					*1 790	1 400	1 220	890	850	620	820	590	5 120
CWT 580kg	1.0 m kg					1 810	1 290	1 170	840	830	600	780	560	5 190
Dozer blade up	0.0 m kg					1 760	1 240	1 130	810	820	590	810	580	5 022
	-1.0 m kg	*2 460	*2 460	*3 140	2 460	1 750	1 230	1 130	800			930	670	4 585
	-2.0 m kg			*2 590	2 520	*1 680	1 270					*1 140	910	3 757
Boom 2.9m	5.0 m kg											*1 050	*1 050	3 611
Arm 1.94m	4.0 m kg							*910	*910			*960	780	4 637
Shoe 400mm	3.0 m kg							*970	*970	*960	680	*910	620	5 209
CWT 580kg	2.0 m kg					*1 490	*1 490	*1 170	960	*1 020	660	*910	550	5 501
Dozer blade down	1.0 m kg					*2 090	1 370	*1 400	890	*1 110	630	*970	530	5 566
	0.0 m kg			*1 500	*1 500	*2 370	1 280	*1 560	840	*1 160	610	*1 040	540	5 412
	-1.0 m kg	*1 960	*1 960	*2 680	2 530	*2 310	1 260	*1 550	820	*1 080	600	*1 070	600	5 017
	-2.0 m kg	*3 090	*3 090	*3 180	2 590	*1 920	1 290	*1 260	840			*1 070	770	4 296
	-3.0 m kg			*1 450	*1 450							*890	*890	2 926
Boom 2.9m	5.0 m kg											*1 050	*1 050	3 611
Arm 1.94m	4.0 m kg							*910	*910			*960	730	4 637
Shoe 400mm	3.0 m kg							*970	950	870	630	810	580	5 209
CWT 580kg	2.0 m kg					*1 490	1 430	*1 170	900	850	620	720	520	5 501
Dozer blade up	1.0 m kg					1 810	1 280	1 160	830	820	590	690	490	5 566
	0.0 m kg			*1 500	*1 500	1 710	1 190	1 110	790	800	560	710	500	5 412
	-1.0 m kg	*1 960	*1 960	*2 680	2 320	1 690	1 170	1 090	770	800	560	790	560	5 017
	-2.0 m kg	*3 090	*3 090	*3 180	2 390	1 720	1 200	1 110	790			1 010	710	4 296
	-3.0 m kg			*1 450	*1 450							*890	*890	2 926
Boom 2.9m	4.0 m kg							*1 110	1 010			*1 130	940	4 155
Arm 1.54m	3.0 m kg							*1 130	1 000			990	730	4 799
Shoe 400mm	2.0 m kg					*1 790	1 500	1 300	960	910	670	880	640	5 120
CWT 690kg	1.0 m kg					1 930	1 380	1 250	910	890	650	840	610	5 190
Dozer blade down	0.0 m kg					1 880	1 330	1 220	880	880	630	870	630	5 022
	-1.0 m kg	*2 460	*2 460	*3 140	2 640	1 880	1 330	1 210	870			1 000	720	4 585
	-2.0 m kg			*2 590	*2 590	*1 680	1 360					*1 140	980	3 757
Boom 2.9m	4.0 m kg							*1 110	1 010			*1 130	940	4 155
Arm 1.54m	3.0 m kg							*1 130	1 000			990	730	4 799
Shoe 400mm	2.0 m kg					*1 790	1 500	1 300	960	910	670	880	640	5 120
CWT 690kg	1.0 m kg					1 930	1 380	1 250	910	890	650	840	610	5 190
Dozer blade up	0.0 m kg					1 880	1 330	1 220	880	880	630	870	630	5 022
	-1.0 m kg	*2 460	*2 460	*3 140	2 640	1 880	1 330	1 210	870			1 000	720	4 585
	-2.0 m kg			*2 590	*2 590	*1 680	1 360					*1 140	980	3 757
Boom 2.9m	5.0 m kg											*1 070	*1 070	3 611
Arm 1.94m	4.0 m kg							*930	*930			*970	870	4 637
Shoe 400mm	3.0 m kg							*990	*990	*980	760	*920	700	5 209
CWT 690kg	2.0 m kg					*1 520	*1 520	*1 190	1 060	*1 040	740	910	630	5 501
Dozer blade down	1.0 m kg					*2 120	1 530	*1 430	1 000	1 040	710	880	600	5 566
	0.0 m kg			*1 510	*1 510	2 250	1 450	1 420	950	1 020	690	910	620	5 412
	-1.0 m kg	*1 970	*1 970	*2 690	*2 690	2 230	1 420	1 400	940	1 010	690	1 010	680	5 017
	-2.0 m kg	*3 100	*3 100	*3 230	2 890	*1 960	1 450	*1 290	950			*1 100	870	4 296
	-3.0 m kg			*1 490	*1 490							*920	*920	2 926
Boom 2.9m	5.0 m kg											*1 070	*1 070	3 611
Arm 1.94m	4.0 m kg							*930	*930			*970	800	4 637
Shoe 400mm	3.0 m kg							*990	*990	950	700	880	650	5 209
CWT 690kg	2.0 m kg					*1 520	*1 520	*1 190	980	930	680	800	580	5 501
Dozer blade up	1.0 m kg					1 960	1 410	1 270	920	900	660	770	550	5 566
	0.0 m kg			*1 510	*1 510	1 870	1 320	1 220	880	880	640	790	570	5 412
	-1.0 m kg	*1 970	*1 970	*2 690	2 550	1 850	1 300	1 200	860	880	630	870	630	5 017
	-2.0 m kg	*3 100	*3 100	*3 230	2 610	1 870	1 320	1 220	870			*1 100	800	4 296
	-3.0 m kg			*1 490	*1 490							*920	*920	2 926

Notes: 1. The above loads are in compliance with SAE J1097 and ISO 10567 Hydraulic Excavator Lifting Capacity Standards. 2. Rated loads do not exceed 87% of hydraulic lifting capacity or 75% of tipping load. 3. Rated loads marked with an asterisk (*) are limited by hydraulic capacity rather than tipping load.

Equipment.

STANDARD EQUIPMENT

Engine

Low-emission Volvo diesel engine
Standard cooling system
Two-stage air filter with indicator
Fuel filter and water separator
Alternator, 60 A

Electric/Electronic control system

Safe engine start function
Automatic idling system
Halogen working lights:
Cab-mounted 2 (front), Boom-mounted 1
Battery, 12 V / 100 Ah
Start motor, 12 V / 3 kW
Travel alarm
Monitor and keypad
Master electrical disconnect switch

Hydraulic system

Automatic two speed travel motors
Cylinder cushioning
Hydraulic fluid mineral 46

Cab and interior

Cab, includes:

Glasses
Cup holders
Large storage area
Door locks
Floor mat

Horn

2 inch Seat belt

Heater and air-conditioner

Fabric operator seat with suspension without heater

Control joystick

Travel pedals and hand levers

AM/FM stereo

Master key

Hour meter (non analog)

Frame

580kg counterweight

Rearview mirror

Under cover

Dozer blade

Undercarriage

Track link

380mm steel track

Digging equipment

Boom: 2.9m, Arm: 1.54m

Linkage

Service

Tool kit, full scale

Spare parts

OPTIONAL EQUIPMENT

Electric/Electronic control system

Fuel filler pump: 35 l/min, with automatic shut-off

Extra working lights:

Cab-mounted 1 (rear)

Caretrack

Anti theft, code-lock

Rotating warning beacon

Hydraulic system

Hydraulic piping:

Breaker & shear (max. flow and pressure: 70lpm, 26.5Mpa)

Slope & rotator (max. flow and pressure: 35lpm, 14.7Mpa)

Grapple

Quick coupler

Hose rupture valve for boom and arm

Overload warning device

Hydraulic oil, ISO VG 32, 68

Hydraulic oil, biodegradable 46

Hydraulic oil, longlife oil 46

Cab and interior

CareCab

Canopy

Fabric operator seat with suspension with heater

PVC operator seat with suspension

Control joystick, X3 proportional

Seat belt, 3 inch retractable

AM/FM stereo with CD player and USB input

Mechanical hour meter

Cab mounted FOG (Falling Object Guard)

FOPS (Falling Object Protection Structure)

Sun screen, front/roof

Safety net

Frame

Dozer blade with floating function

Undercarriage / Superstructure

500mm steel track

400mm rubber track and rubber pad

Heavy counterweight

Digging equipment

Arm: 1.94m

Service

Tool kit-daily maintenance

OFFICIAL APPROVAL

Object handling device conforming to ISO20474-1 and ISO20474-5 standards (when equipped)

FOPS Level 2 conforming to ISO3449 standard (when equipped)

ROPS conforming to ISO12117-2 standards

TOPS conforming to ISO12117 and EN13531 standards

FOG Level 2 conforming to ISO10262 standard and SAE J1356 standard (when equipped)

SELECTION OF VOLVO OPTIONAL EQUIPMENT

Slope and rotator piping



Dozer float



Caretrack



Fuel filler pump



Mechanical hour meter



Anti-theft



VOLVO

Volvo Construction Equipment

www.volvoce.com